



Surge Protective Device

**PC642C Series**  
Zone/Loop/Data (Modular)

Technical Documentation



ACCESSORY SOLD SEPARATELY

The **PEMCO PC642C Series** surge protective device (SPD) is a two-pair (four wire) module implementing three-stage hybrid technology. This SPD addresses over-voltage transients with gas tubes and silicon avalanche components. In addition, sneak and fault currents are mitigated with resettable fuses (PTCs). The PTCs increase resistance several orders of magnitude when over-currents exceed safe levels. A normal state resumes when over-currents are removed. The ability to self-restore in this manner significantly increases suppressor performance and survivability.

The PC642C card edge is gold-plated, double sided and is designed to mate with the base accessory (PCB1B) gold-plated female terminal connector (sold separately). When snapped together, the data circuits “pass thru” the protector in a serial fashion from the four “Field Side” terminals to the four “Electronics Side” terminals. Terminals 1 or 10 of the PCB1B must be attached to Building-Approved Ground.

#### General Technical Specifications

Operating Voltage	5, 12, 18, 24, 30, 36, 43, 52 VDC
Clamping Voltage	8, 15, 20, 30, 36, 43, 50, 60 VDC
Operating Current	0.15 A
Peak Surge Current	10 kA (8 x 20 $\mu$ s)
Frequency Range	0 to 20 MHz
Insertion Loss	< 0.1 dB at 50 MHz
SPD Technology	GDT, SAD, w/ Series PTC
Connection Type	Terminal Block, w/ compression lugs Terminals accept up to 10 AWG
Operating Temperature	-40°C to +85°C
Dimensions (in / mm)	2.0" H x 1.0" W x 2.5" L [50.8 x 25.4 x 63.5 mm] (175 + PCB1B Base)
Weight (oz / kg)	1 oz [0.03 kg]
Certifications	UL 497B

#### Caution

Do not place this product in service on any signal line capable of supplying more than 150 mA continuously.

## Key Specs

- **Voltage:** 0-250 VDC
- **Current:** 150mA
- **Connection:** Modular; Hardwire into base
- **Mounting:** Punch into keyed base/DIN

\*See Ordering Information for model number selection

## Features

- Three-stage hybrid protection
- Sneak/fault current protection
- Resettable fuses – PTCs
- Low capacitance option
- Plug-in module
- Fast response time
- 5 year warranty

## Certifications

- UL 497B



**DANGER!**

Only qualified personnel should install or service this system. Electrical safety precautions must be followed when installing or servicing this equipment. To prevent risk of electrical shock, turn off and lock out all power sources to the unit before making electrical connections or servicing.

## Installation Instructions

### DRAWING 1

PCB1B Accessory Terminal Assignments

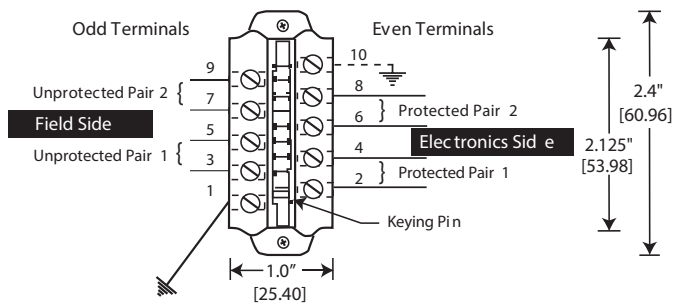

Ground Terminal 1 or 10 to Building Approved Ground (preferably AC Power safety ground).

NOTE: DO NOT daisy chain grounds. NOT intended for shield termination. Install ground in accordance with all applicable codes.

### DRAWING 2

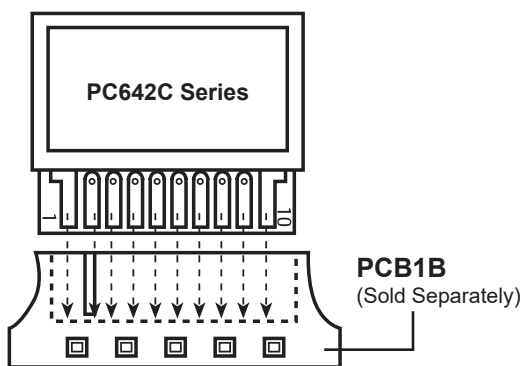

## Read and Understand These Instructions

### Note:

- These protectors are intended for indoor use on communication loop circuits which have been isolated from the Public Switch Telephone Network.
- The communication loop circuits shall not be exposed to accidental contact with the electric light or power conductors.
- The protectors shall be installed per the applicable requirements of the National Electric Code, ANSI/NFPA 70.
- Measure DC operating voltage of system to insure it does not exceed the rating of the selected surge device (5-180 VDC depending on the device).

### Installation:

1. Turn off power to circuit to be protected prior to installation.
2. Screw mounting base #PCB1B (accessory) in desired location preferably as close to protected equipment as possible and in close proximity to a building approved grounding point using (2) #4 screws. PCB1B may also be DIN Rail mounted using optional DIN clip accessory #PCDIN.
3. Attach field side pairs (26-10 AWG) to positions 3/5 and 7/9, attach electronics side pairs (26-10 AWG) to positions 2/4 and 6/8. Attach ground wire (10 AWG) to positions 1 or 10 on base. See Drawing 1. Torque wires to 7 lb-in [0.791 N-m].
4. Insert 175 module into keyed PCB1B base. See Drawing 2.
5. Apply power to protected circuit.

KENICK  
11400 47th St N Ste A  
Clearwater, FL 33762  
Phone: (800) 362-9997  
www.KENICK.com



## Ordering Information

MODEL	OPERATING VOLTAGE	CLAMPING VOLTAGE
PC642C-008P	5 VDC	8 VDC
PC642C-015P	12 VDC	15 VDC
PC642C-020P	18 VDC	20 VDC
PC642C-030P	24 VDC	30 VDC
PC642C-036P	30 VDC	36 VDC
PC642C-043P	36 VDC	43 VDC
PC642C-050P	43 VDC	50 VDC
PC642C-060P	52 VDC	60 VDC
PC642C-008DP	5 VDC	8 VDC
PC642C-015DP	12 VDC	15 VDC
PC642C-020DP	18 VDC	20 VDC
PC642C-030DP	24 VDC	30 VDC
PC642C-036DP	30 VDC	36 VDC
PC642C-043DP	36 VDC	43 VDC
PC642C-050DP	43 VDC	50 VDC
PC642C-060DP	52 VDC	60 VDC
PC642C-008XP	5 VDC	8 VDC
PC642C-015XP	12 VDC	15 VDC
PC642C-020XP	18 VDC	20 VDC
PC642C-030XP	24 VDC	30 VDC
PC642C-036XP	30 VDC	36 VDC
PC642C-043XP	36 VDC	43 VDC
PC642C-050XP	43 VDC	50 VDC
PC642C-060XP	52 VDC	60 VDC
PC642C-008LCP	5 VDC	8 VDC
PC642C-036LCP	30 VDC	36 VDC
PC642C-043LCP	36 VDC	43 VDC

D = Stage 2 clamp line to line only

X = Stage 2 clamp line to line and each line to ground

LC = Low Capacitance option stage 2 clamp line to line and each line to ground

### ACCESSORIES Former Accessory Name

PCB1B	PCB1B-WKEY	Wiring Base, Plug-in Socket
PCDIN	11604KIT-PC	DIN Mounting Kit for PCB1B
PTU	PC642PTU	Pass Through Module for Troubleshooting

### APPLICATIONS

### MODELS

RS485, RS422	175D008S10KLPCN0 & PCB1B
RS423, Token Ring	175D008S10KLPCN0 & PCB1B
RS232	175D020S10KAPCN0 & PCB1B
E-Net, 10 Base T	175D030S10KLPCN0 & PCB1B
4-20 ma	175D036S10KLPCN0 & PCB1B



While every precaution has been taken to ensure accuracy and completeness herein, Kenick assumes no responsibility, and disclaims all liability, for damages resulting from use of this information or for any errors or omissions. Specifications are subject to change without notice.